

CUERPOS GEOMÉTRICOS Y POLÍGONOS

INTRODUCCIÓN

Este ejercicio está diseñado para jugar con los CUERPOS GEOMÉTRICOS en Educación Primaria (Tercer Nivel). Dentro de este tema conoceremos:

- Tipos de Cuerpos Geométricos (PRISMAS, PIRÁMIDES, CONOS, CILINDROS, ESFERAS).
- Elementos de los CUERPOS GEOMÉTRICOS (CARAS, ARISTAS, VÉRTICES).
- Los polígonos y sus elementos (LADOS, VÉRTICES, ÁNGULOS).
- Clases de polígonos (TRIÁNGULOS, CUADRILÁTEROS, PENTÁGONOS, HEXÁGONOS).

PREGUNTAS

1. NOMBRA LOS SIGUIENTES CUERPOS GEOMÉTRICOS.

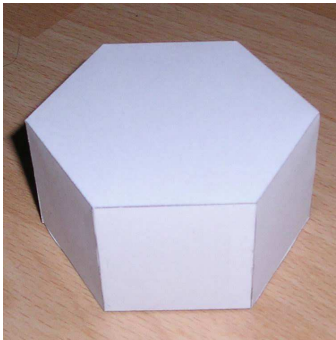

A



B

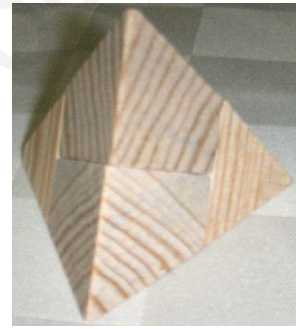

C



D

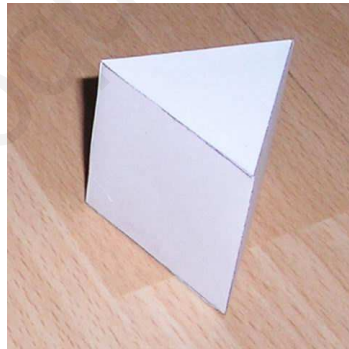

E



F

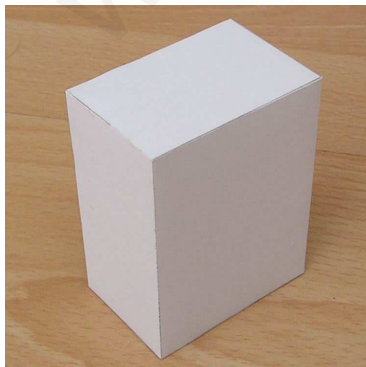

G

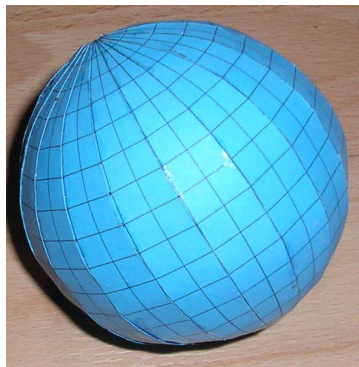

H

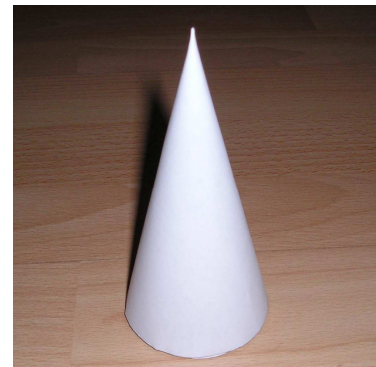

I

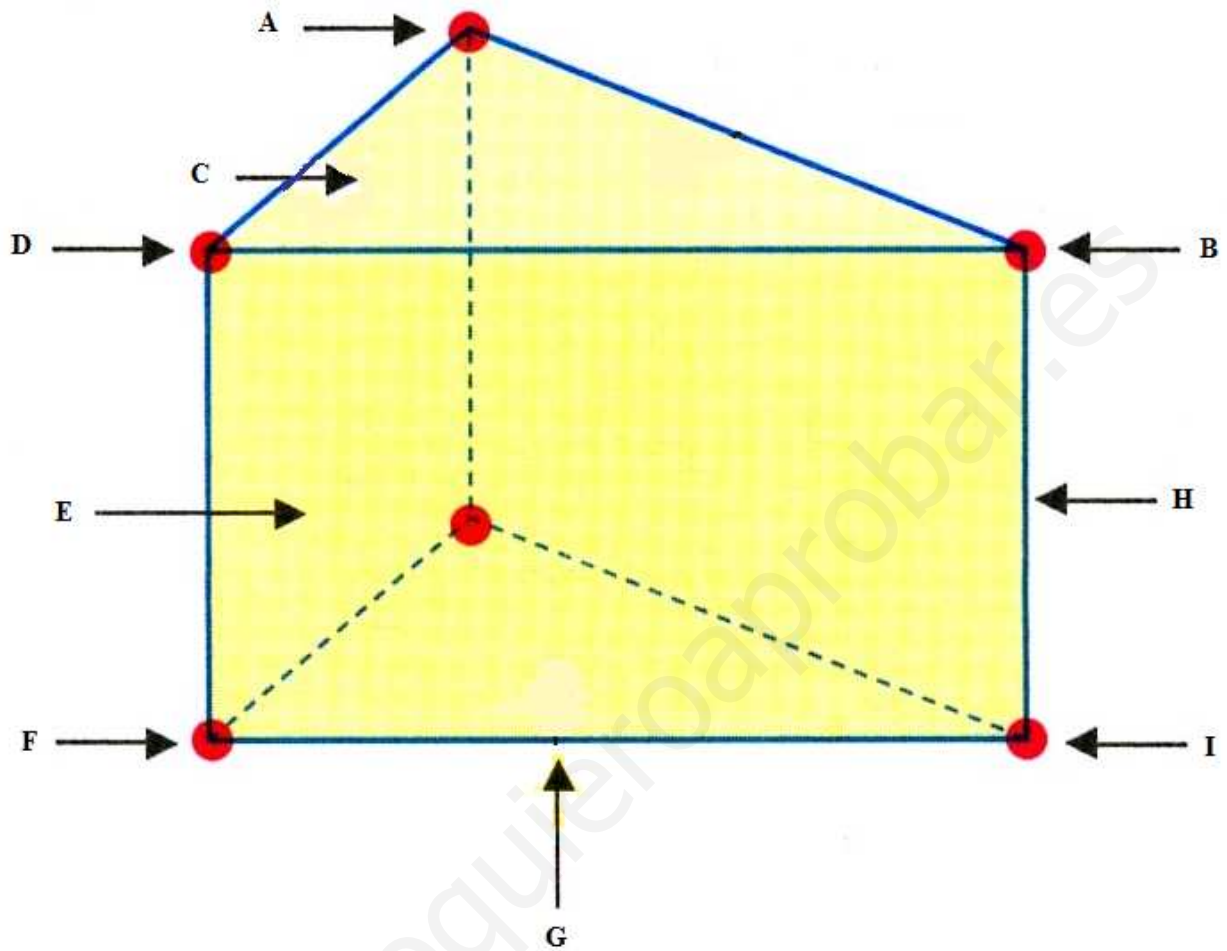

2. COMPLETA LA SIGUIENTE TABLA CON LOS ELEMENTOS DE LOS CUERPOS GEOMÉTRICOS: VÉRTICE, CARA O ARISTA.

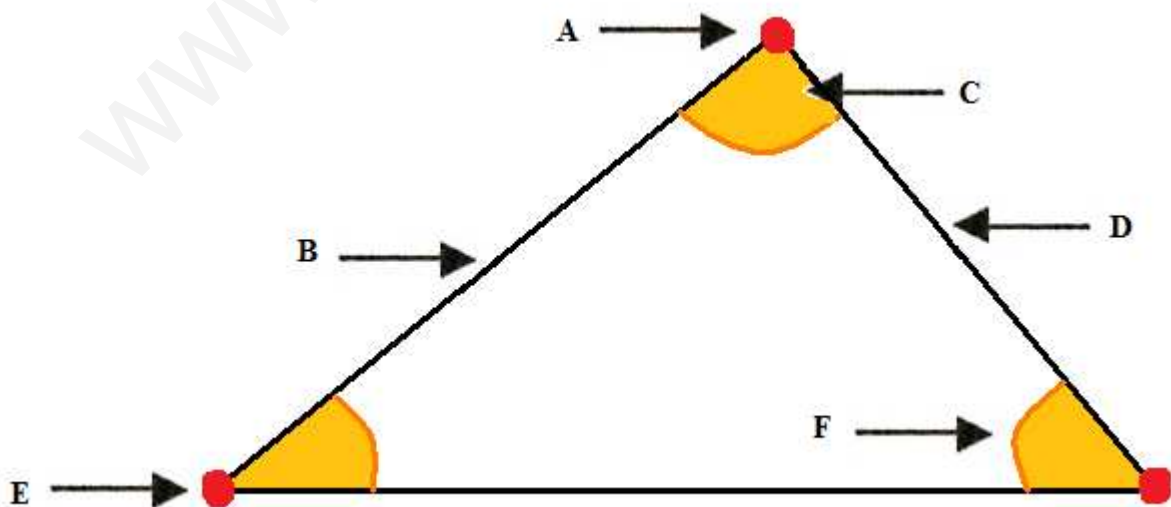

3. COMPLETA LA SIGUIENTE TABLA CON LOS ELEMENTOS DE UN POLÍGONO: LADO, VÉRTICE O ÁNGULO.

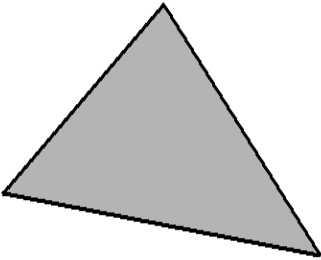
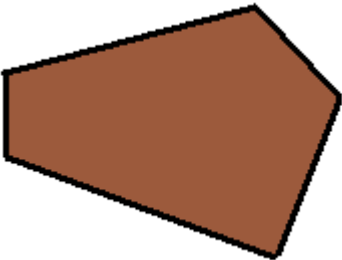
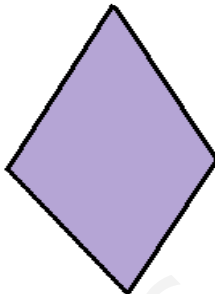
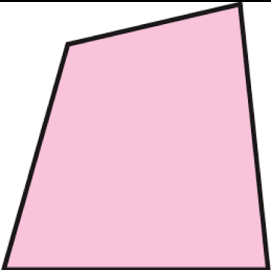
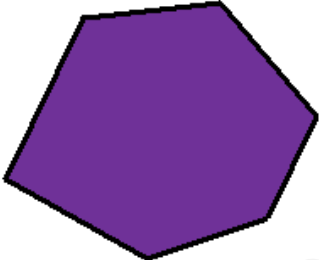
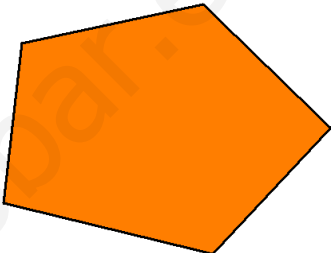
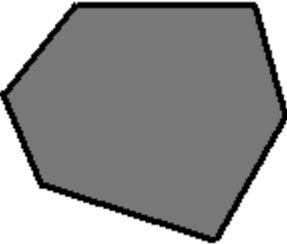

4. NOMBRA LOS SIGUIENTES POLÍGONOS.

		
A	B	C
		
D	E	F
		
G	H	I

FICHA DE REPASO UNIDAD: CUERPOS GEOMÉTRICOS Y POLÍGONOS

1 Rodea los objetos con forma de prisma y colorea de rojo los que tienen forma de cilindro:

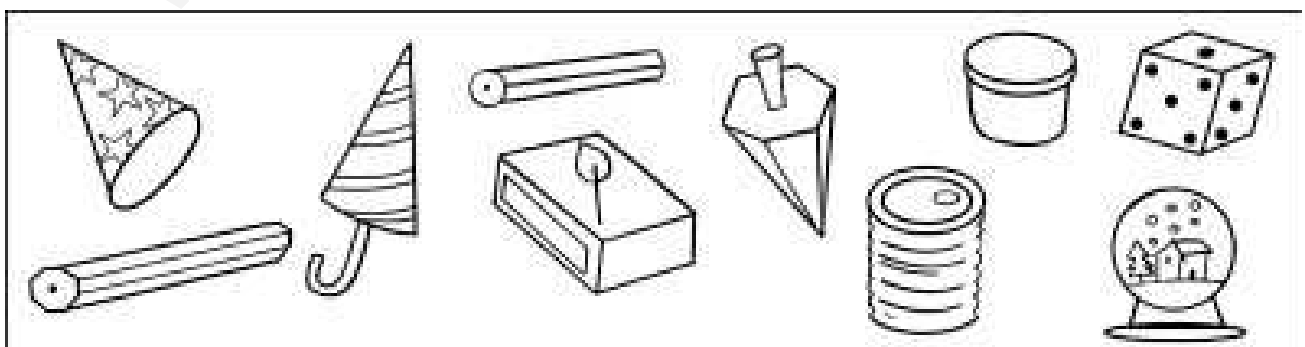

2 Escribe los nombres de estos cuerpos geométricos:

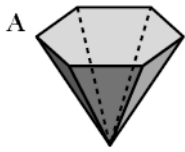

.....

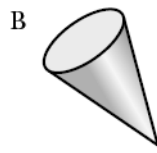

.....

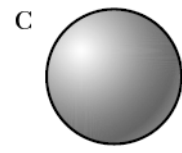

.....

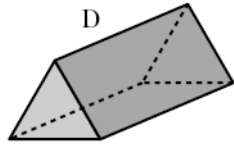

.....

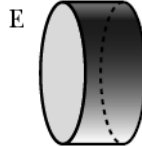

.....

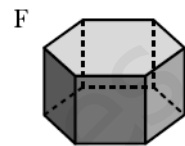

.....

3 Nombra los elementos que se señalan en la pirámide.

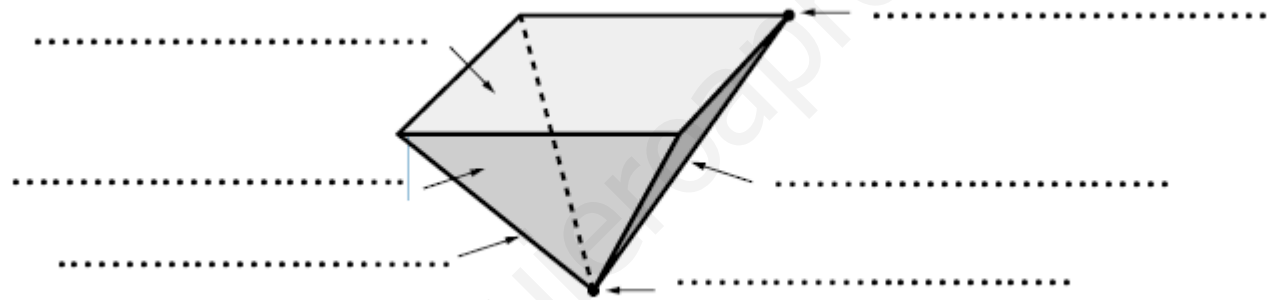

4 Colorea, entre estas figuras planas, las que coinciden con alguna de las caras del prisma:

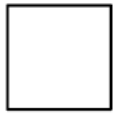
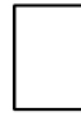
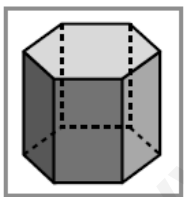

5 Colorea los polígonos.

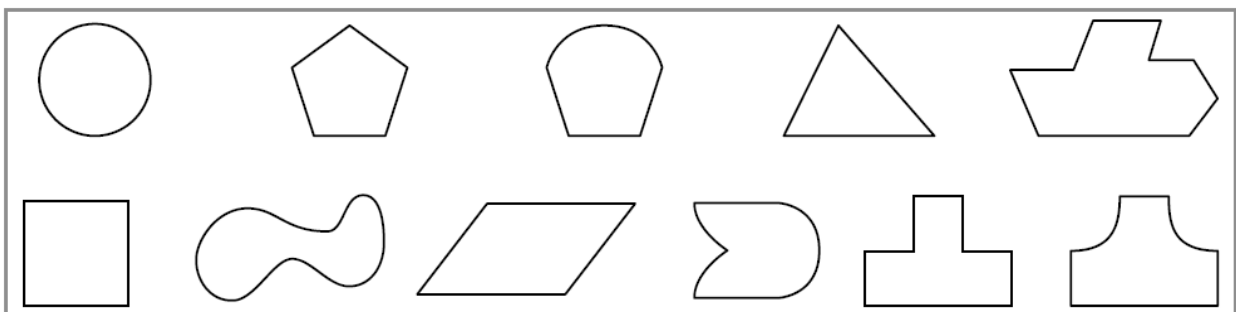

6 Nombra los elementos que se señalan.

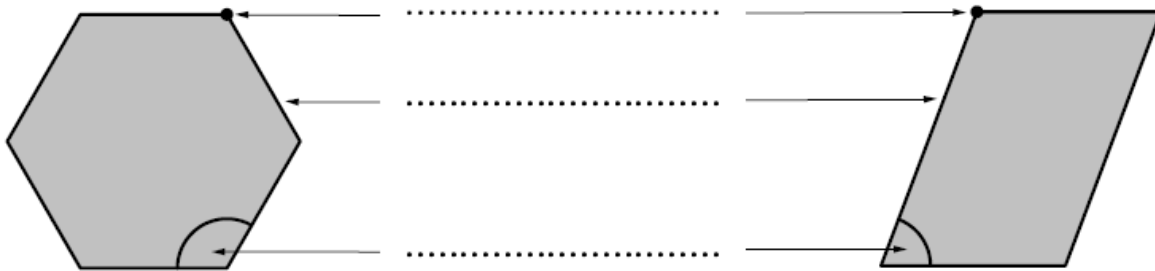

7 Nombra cada polígono según el número de lados.

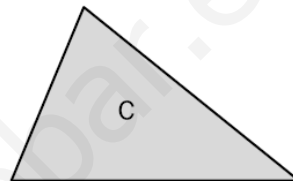
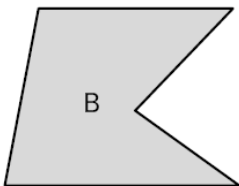
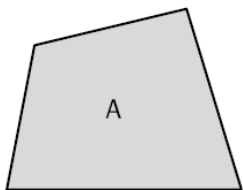

.....

.....

.....

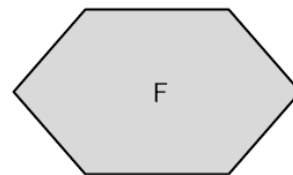
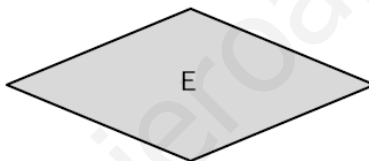
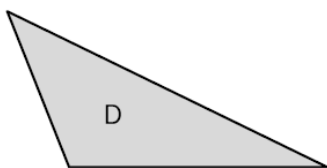

.....

.....

.....

8 Rodea los prismas.

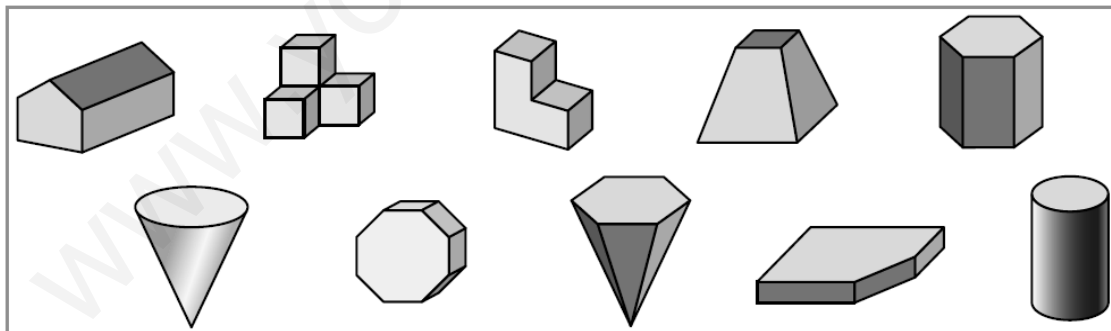

9 Dibuja las huellas que dejaría este cuerpo al apoyarlo sobre una superficie de plastilina:



10 Escribe junto a cada recortable la letra de la figura que le corresponde y colorea, además, del mismo color cada figura y su recortable.

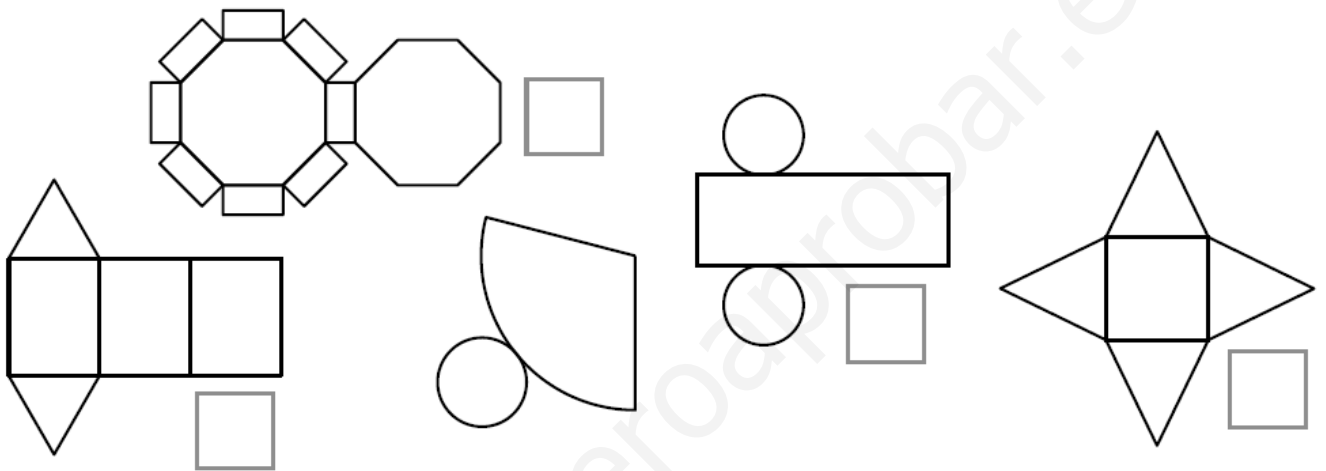
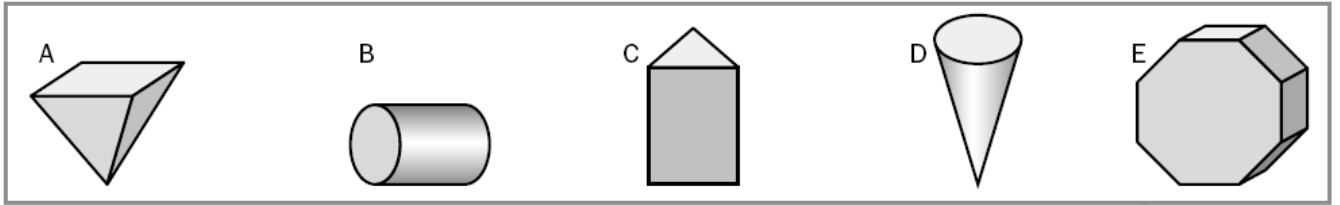

11 Describe los parecidos y las diferencias.

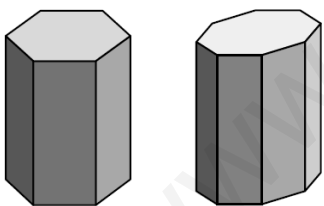

Parecidos:

.....

.....

.....

Diferencias:

.....

.....

.....

12 Cuenta y completa.

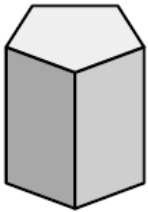

CARAS	
ARISTAS	
VÉRTICES	



CARAS	
ARISTAS	
VÉRTICES	

13 Nombra las caras de cada figura igual que se hace en el ejemplo.

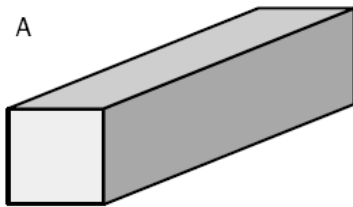

2 cuadrados

4 rectángulos

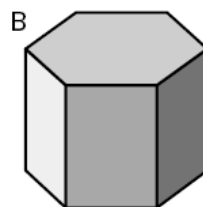

.....

.....

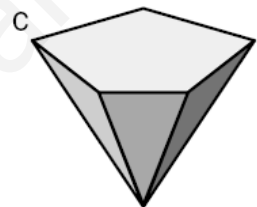

.....

.....

14 Nombra estos polígonos según el número de lados:

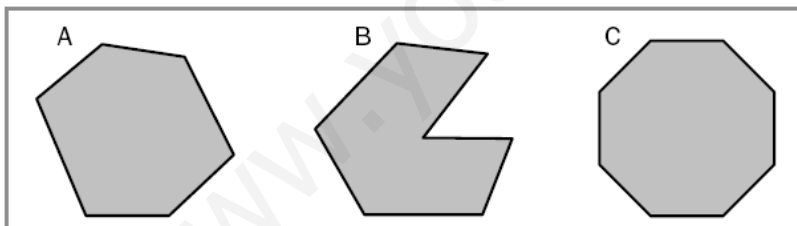

A →

B →

C →