

1. **Dibuja las vistas de las piezas de la derecha. Colorea cada cara de la perspectiva y su vista correspondiente con un mismo color.**

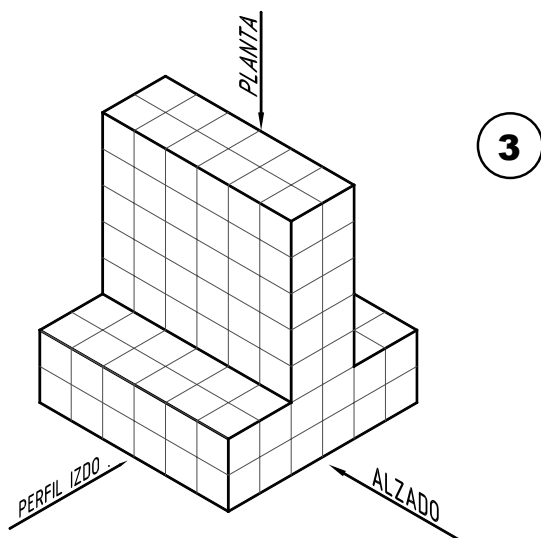

2. Dibuja las vistas de las piezas de la derecha.

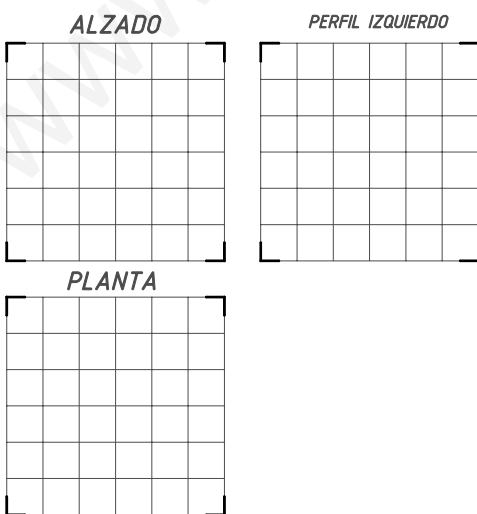
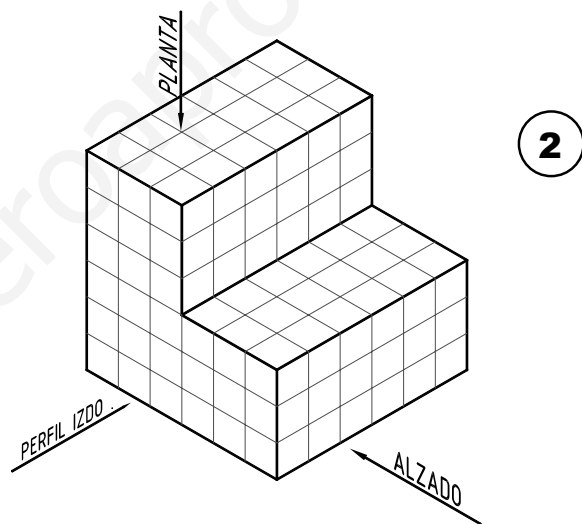
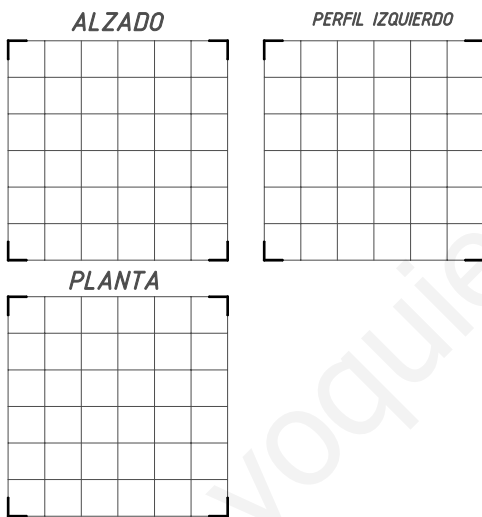
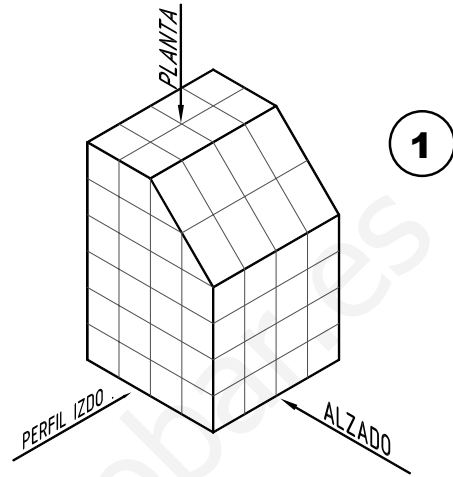
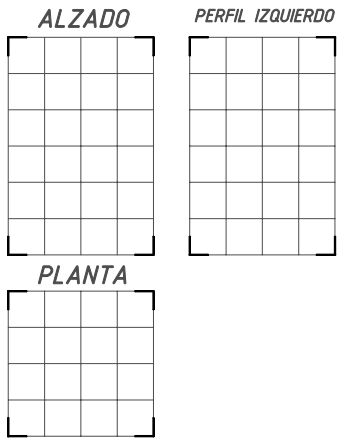
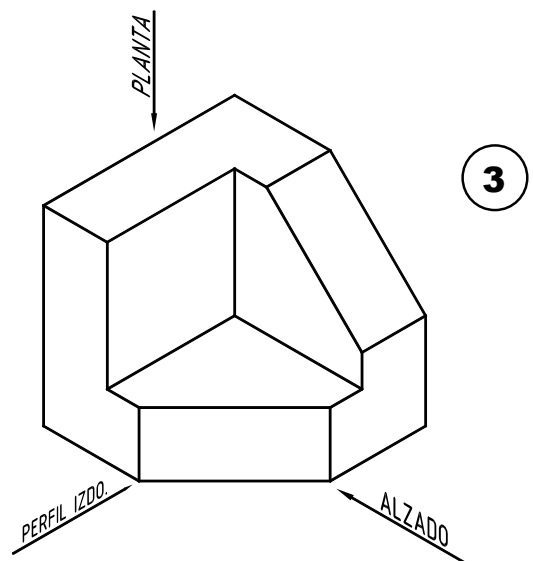
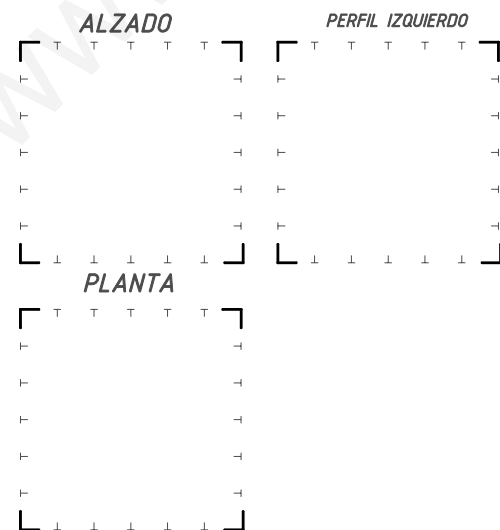
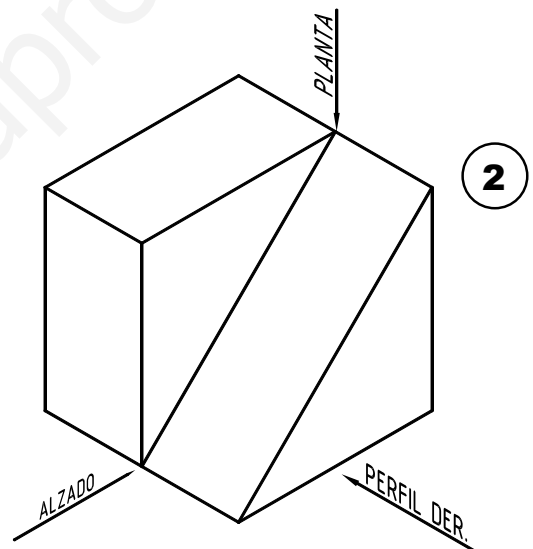
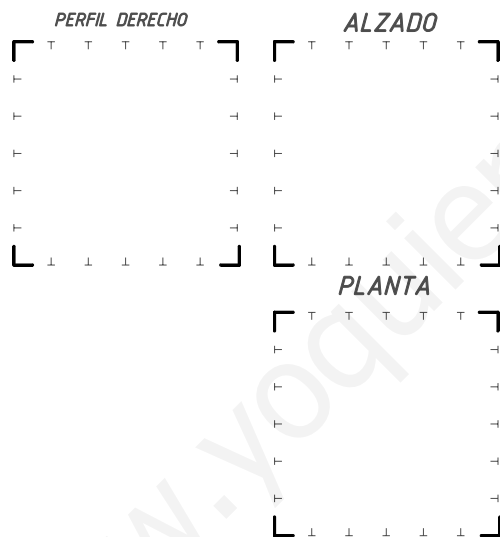
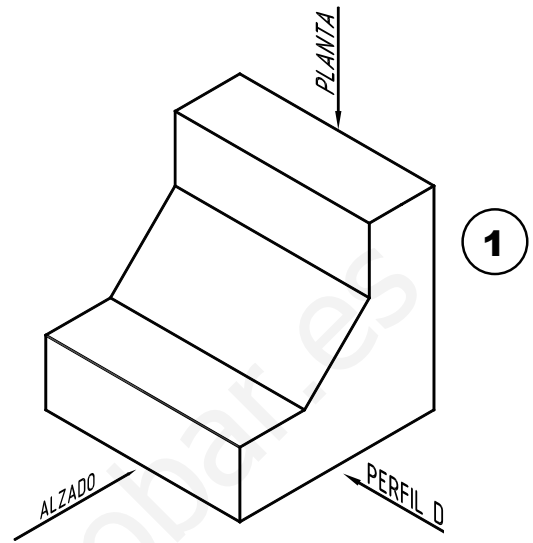
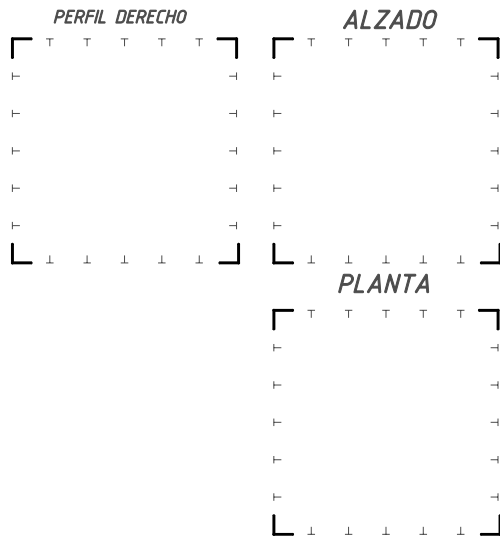

3. *Dibuja las vistas de las piezas de la derecha. Elige el punto de vista más adecuado.*

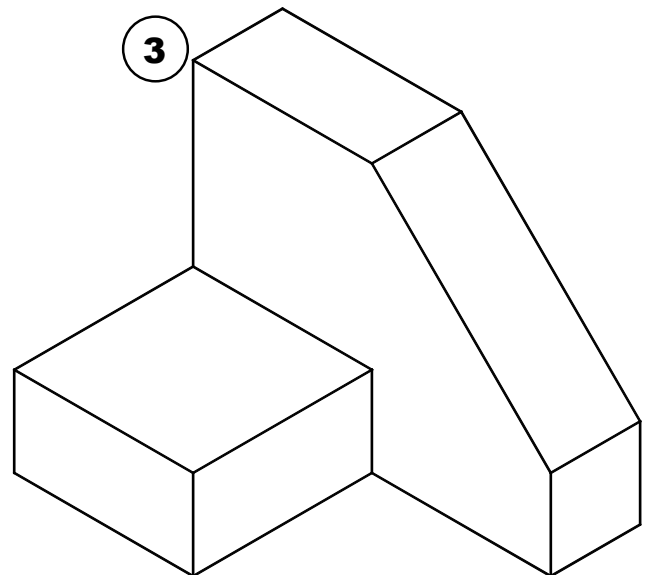
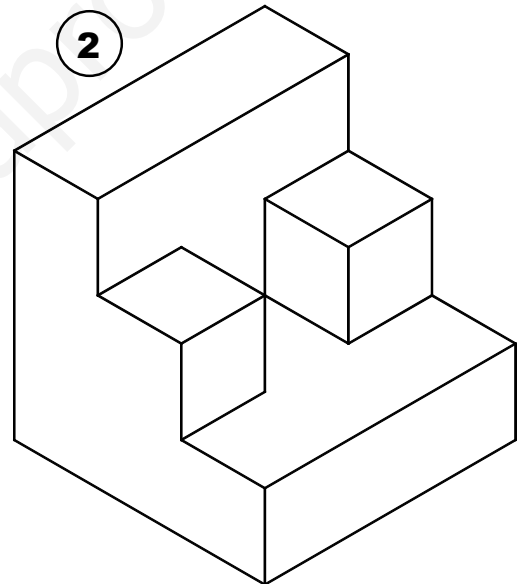
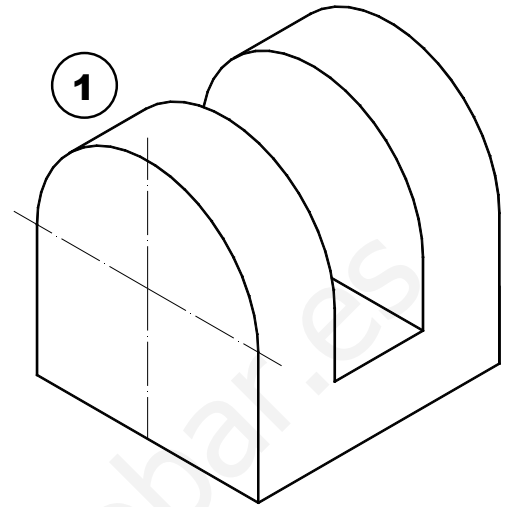

4. Dibuja las tres vistas principales de las siguientes piezas:

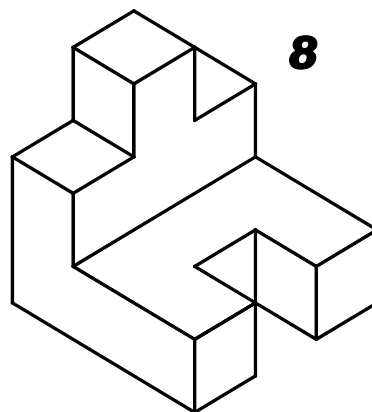
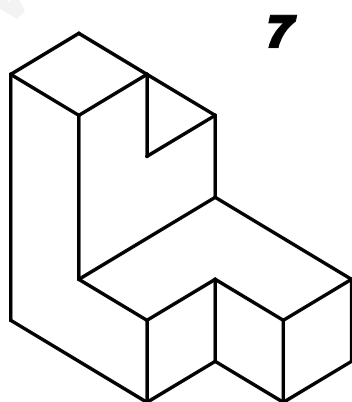
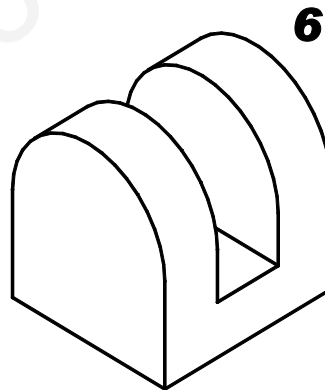
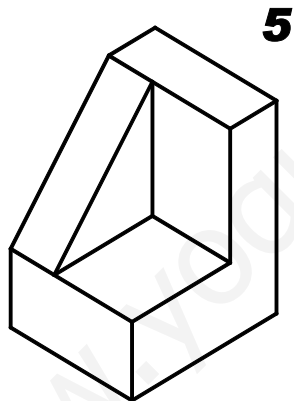
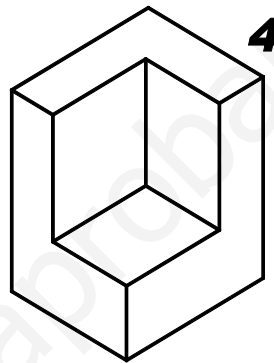
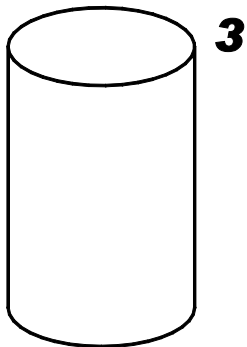
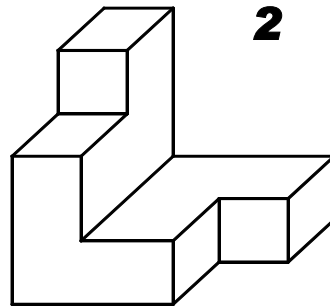
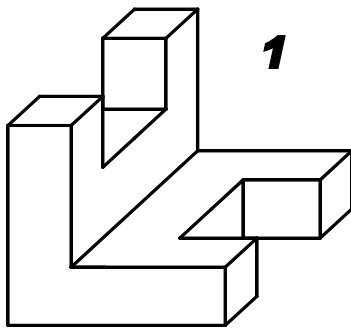

5. Dibuja las vistas de las siguientes piezas respetando las dimensiones que se indican.

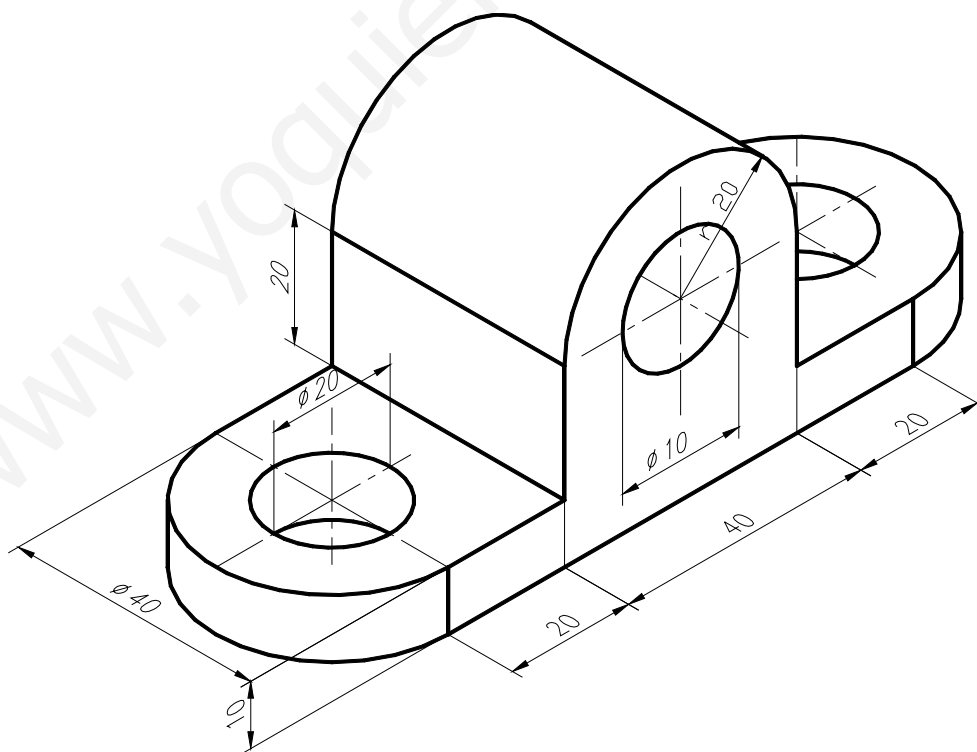
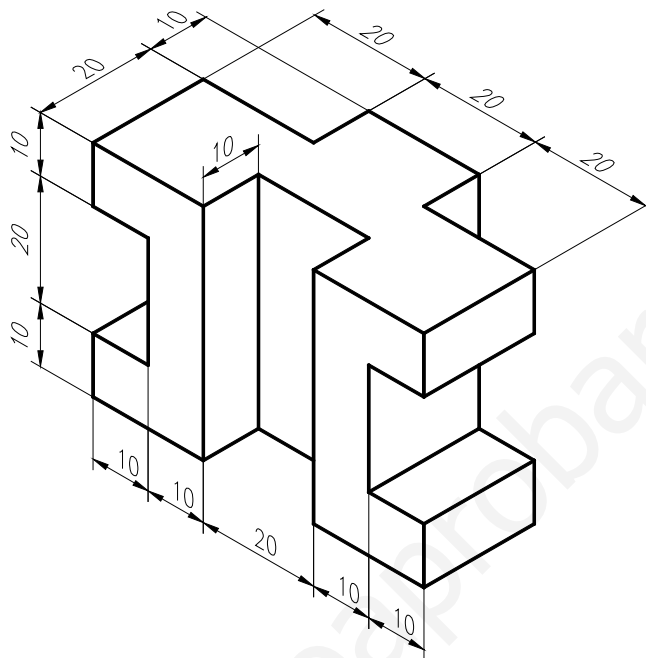

6. Dibuja las vistas de las piezas siguientes, aplicando la escala que se indica junto a ellas. Acótalas correctamente.

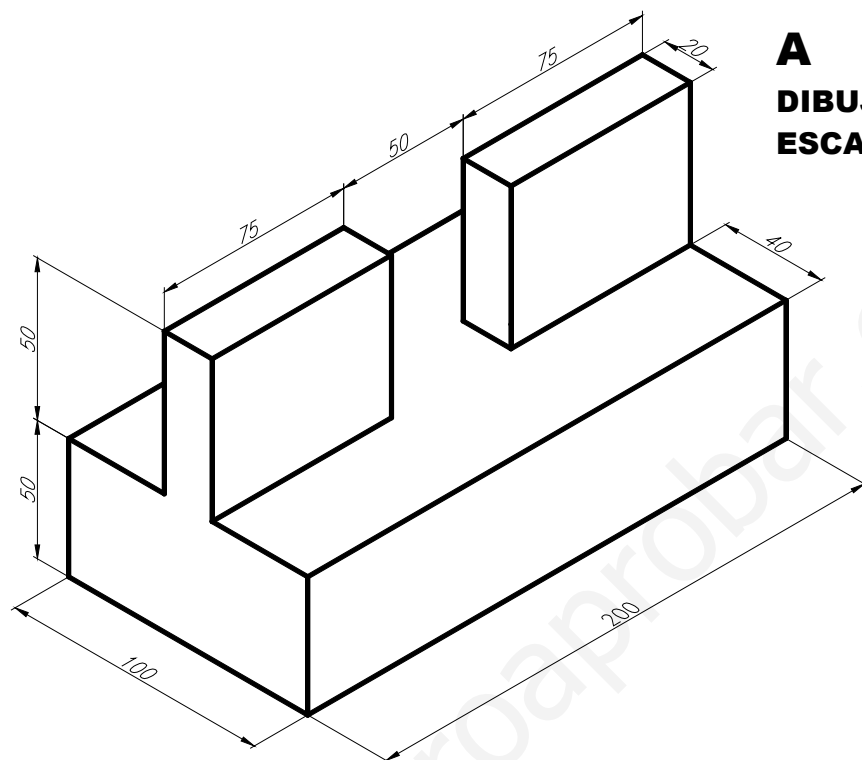

**A**  
DIBUJAR A  
ESCALA 1:2

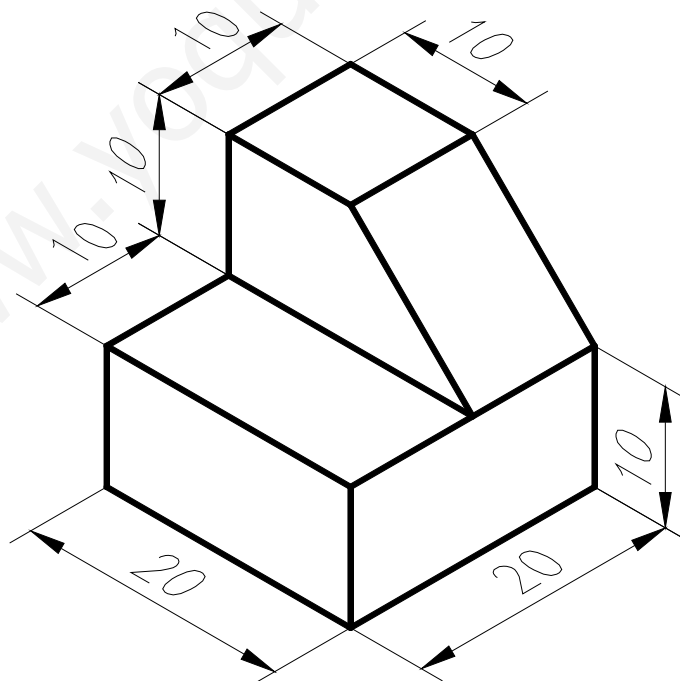

**B**  
DIBUJAR A  
ESCALA 2:1

