

NOMBRE		APELLIDOS		CURSO
--------	--	-----------	--	-------

Indica, para cada caso, cuál o cuáles de las siguientes figuras están bien acotadas. Indica el por qué.:

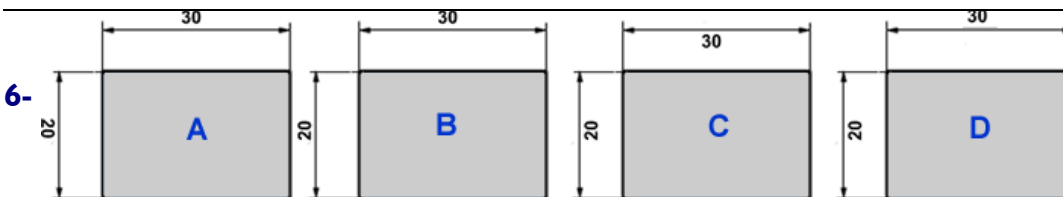

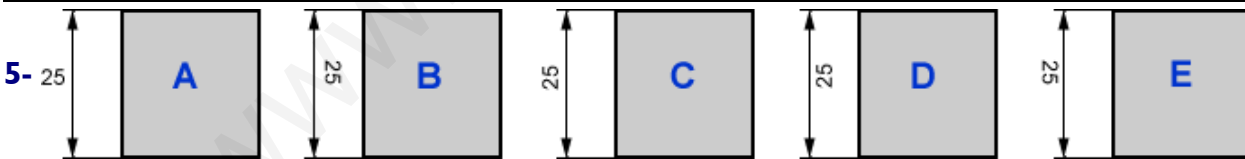

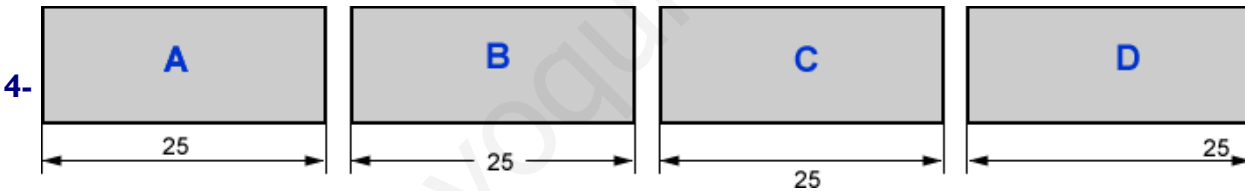
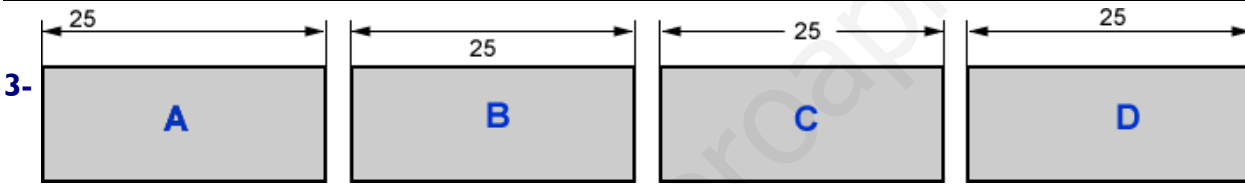
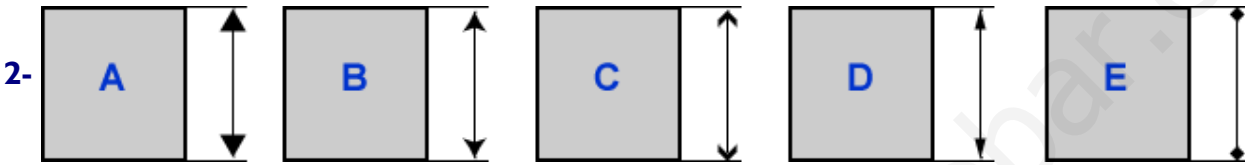
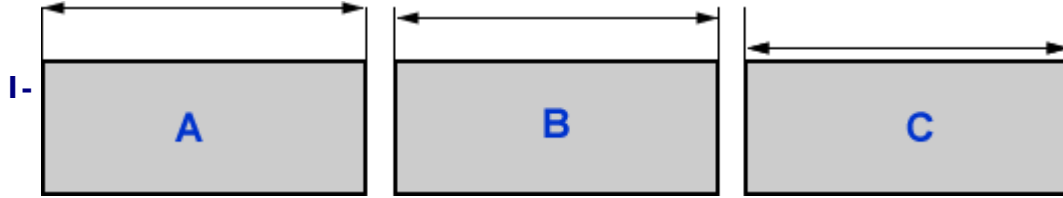
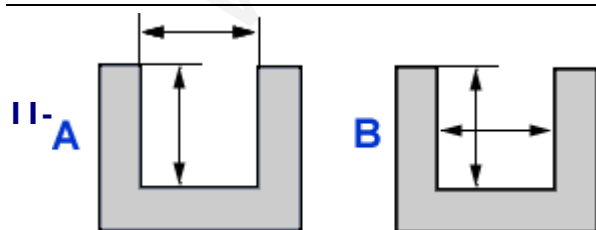
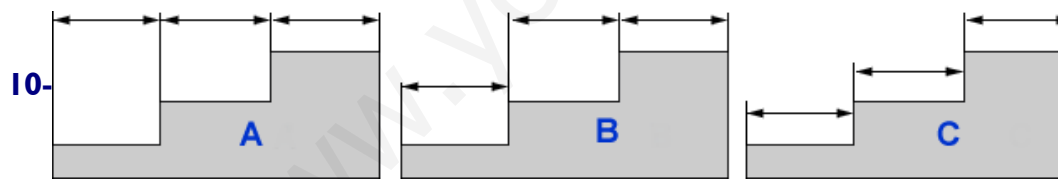
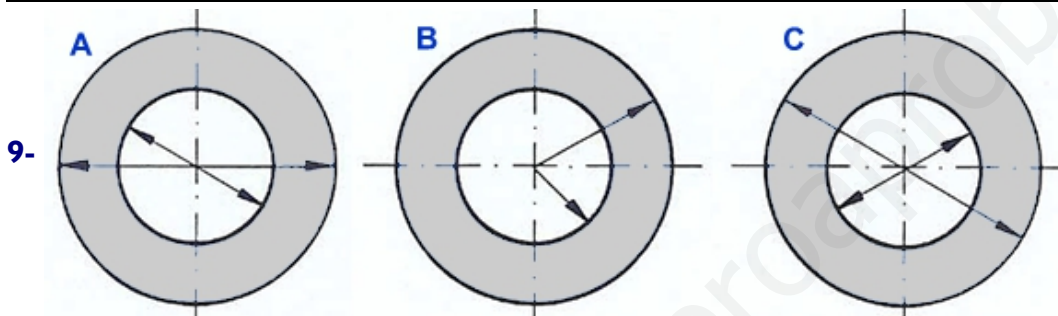
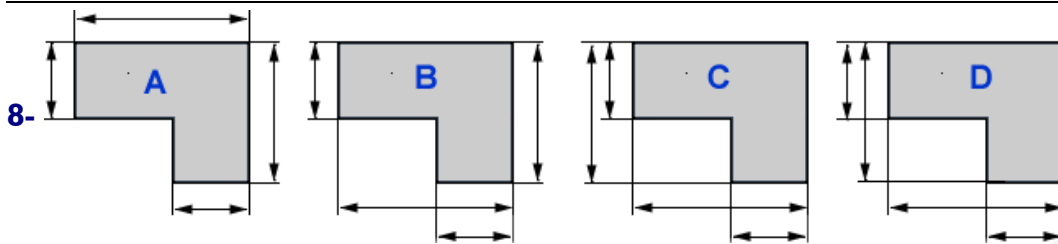
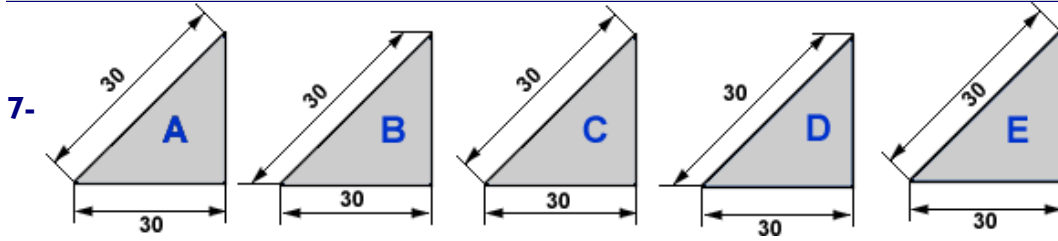
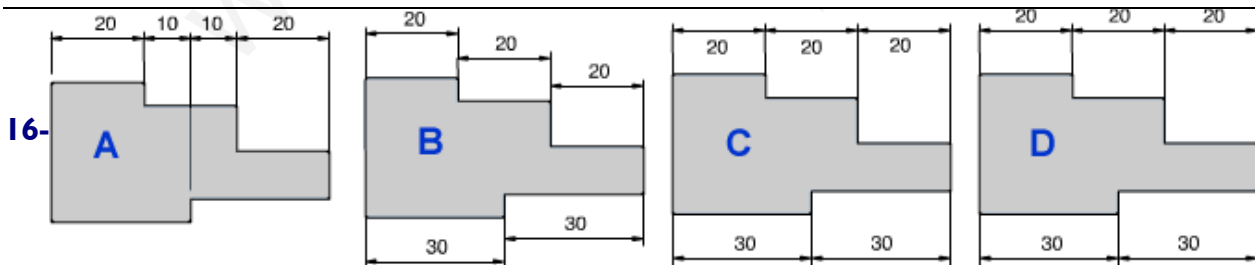
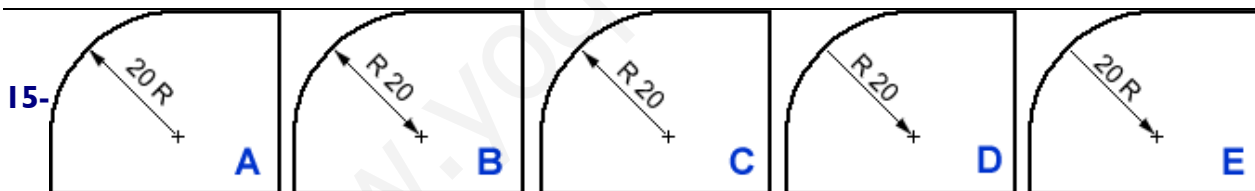
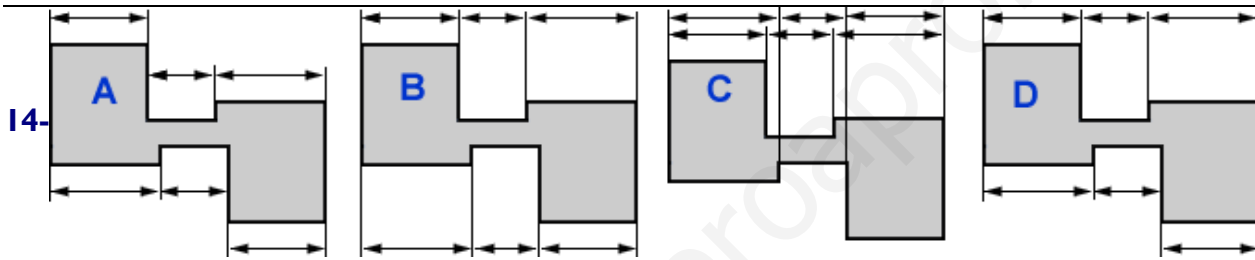
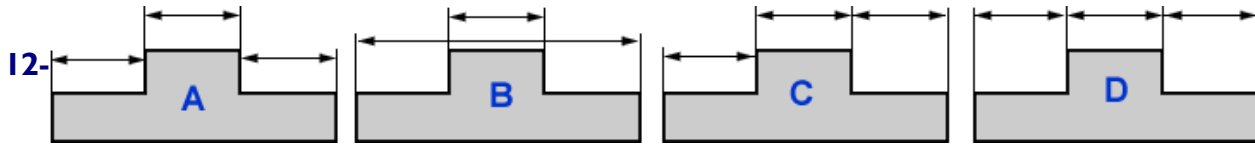

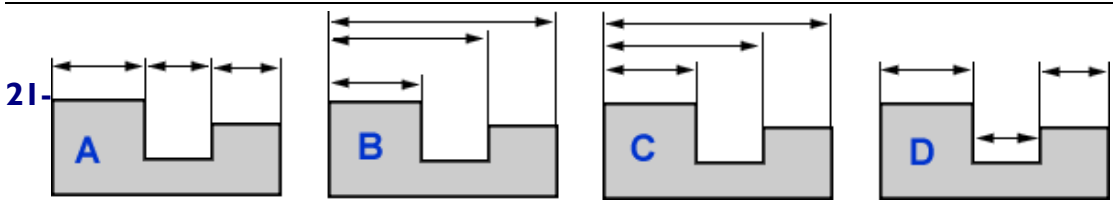
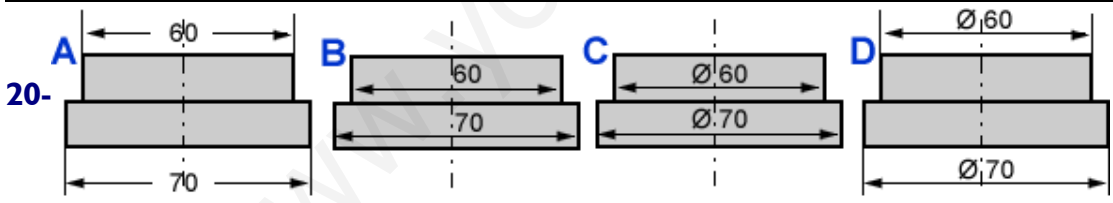
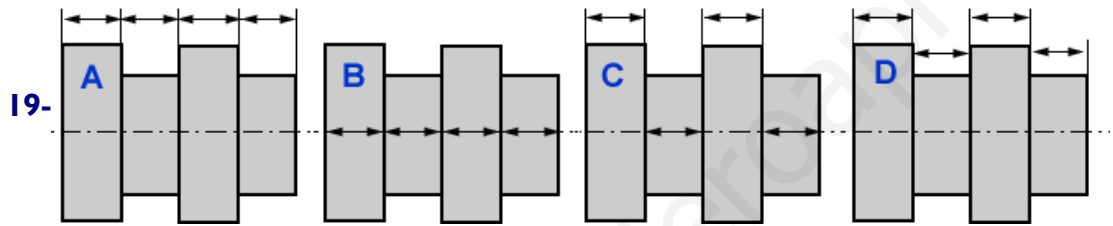
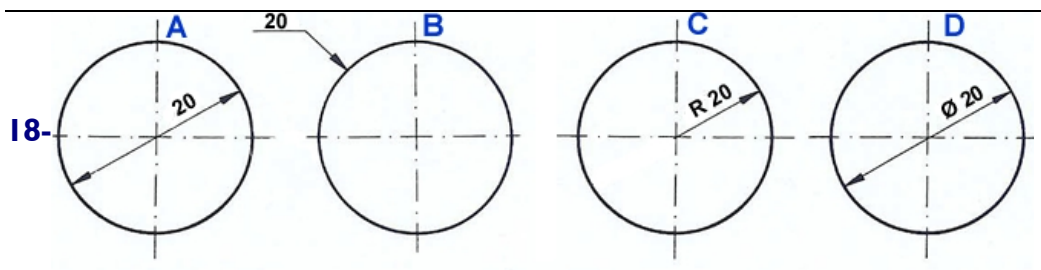
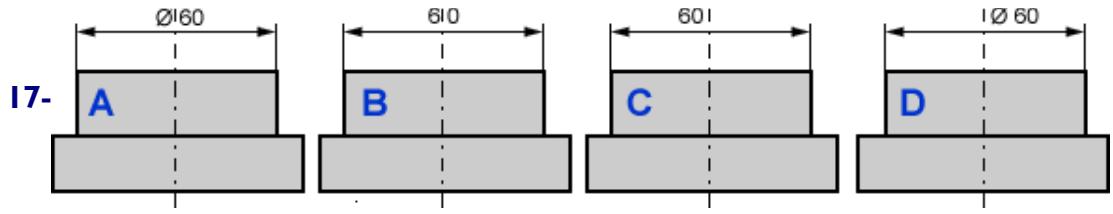

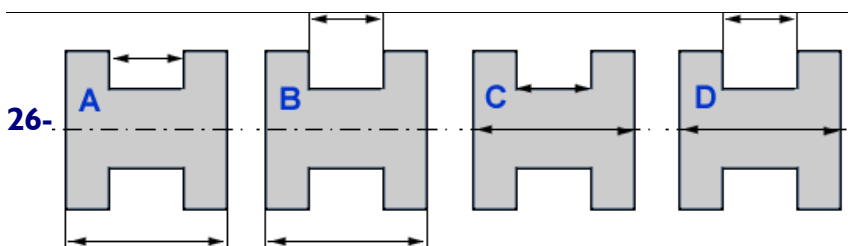
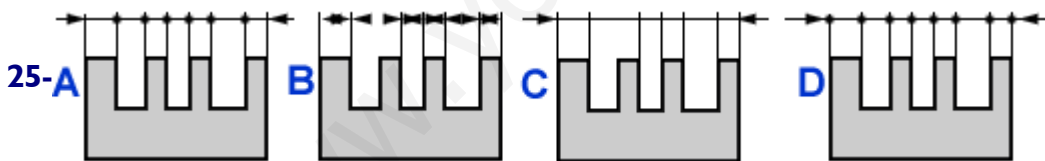
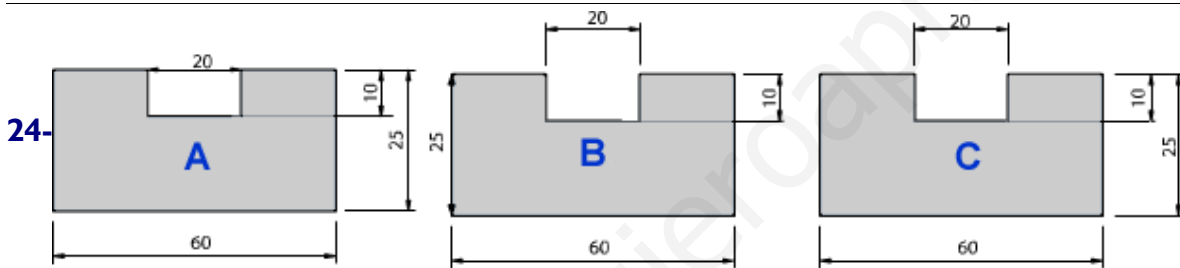
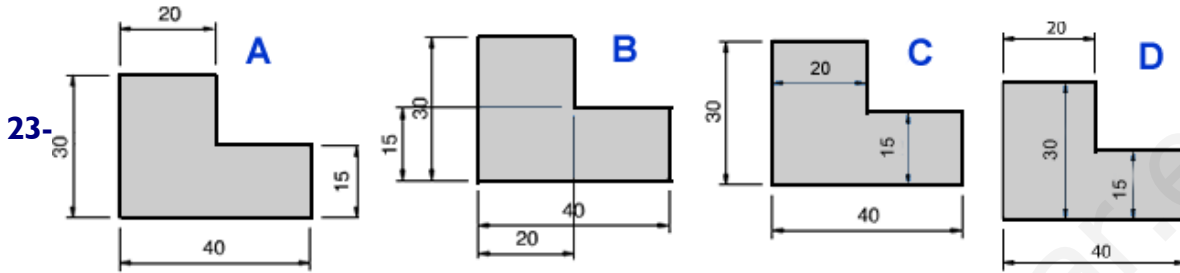
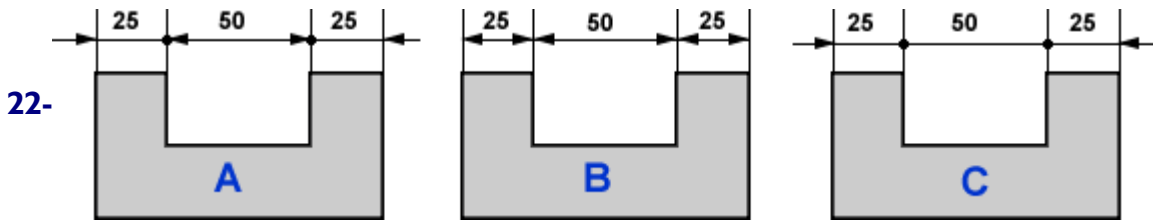

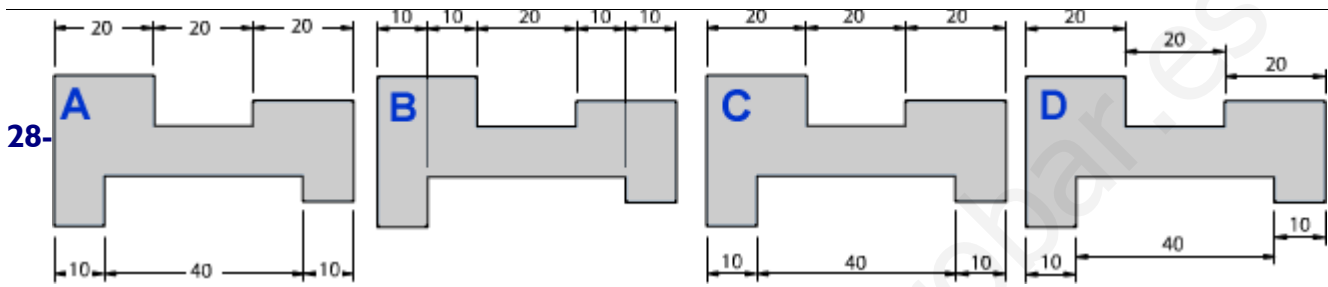
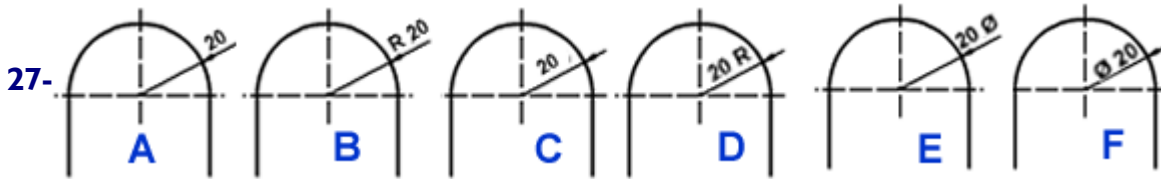

www.yoquieroaprof.com

NOMBRE		APELLIDOS		CURSO	
---------------	--	------------------	--	--------------	--

1. Acota, respetando las normas de acotación, las siguientes figuras, que están representadas a escala 1:5

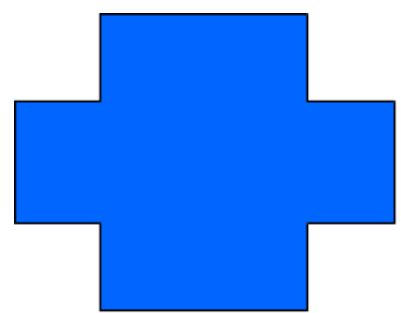
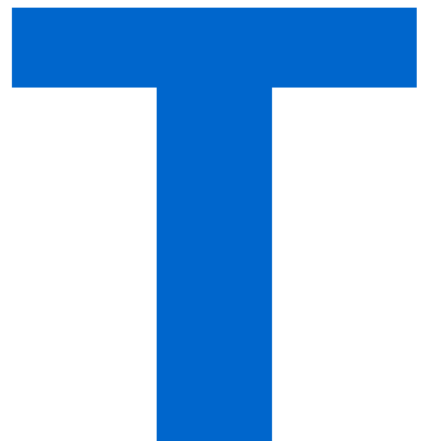

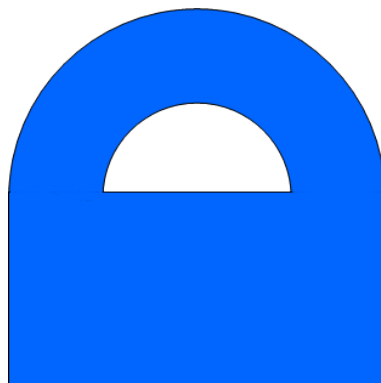
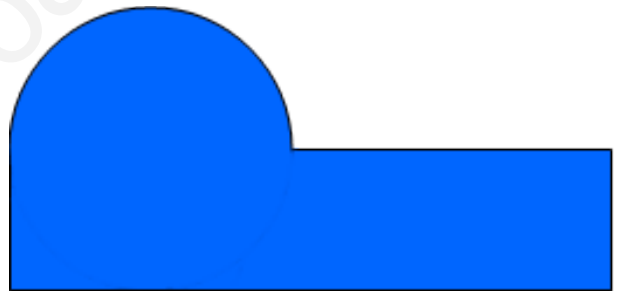
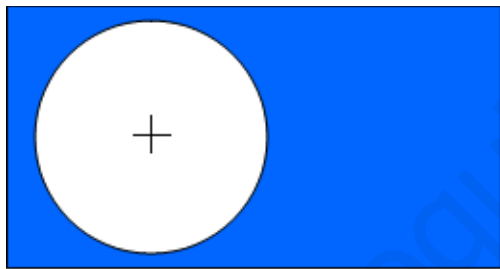
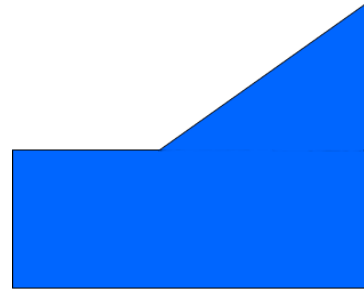
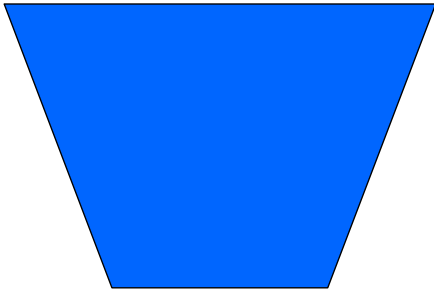

www.youtuberoaprofesor.es