

(Geometry\_Trigonometry)

1. A tower casts a shadow of 64 feet. A 6-foot tall pole near the tower casts a shadow 8 feet long. How tall is the tower? (1 point)

2. A fireman rests his ladder against a building, making a  $57^\circ$  angle with the ground. The bottom of the ladder is 28 feet from the base of the building. How long is the ladder? (1 point)

3. In each triangle find the missing length (write the steps you have taken to reach the solution): (3 points)

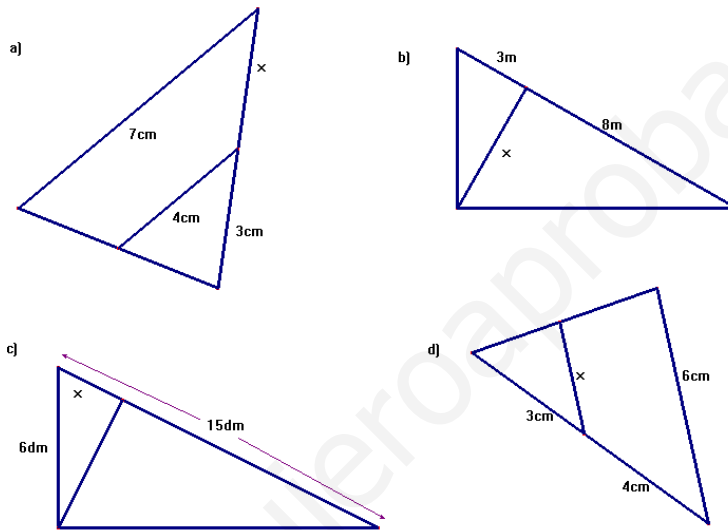

4. A rhombus has sides of length 8 cm and two congruent angles of  $130^\circ$ . Find the length of the longer diagonal of the rhombus and the other angles. (1.75 points)

5. Solve the simultaneous equations: 
$$\left. \begin{aligned} y^2 - 2y + 1 &= x \\ \sqrt{x} + y &= 5 \end{aligned} \right\} \text{ (1.75 points)}$$

6. In each triangle find the missing lengths and/or angles (write the steps you have taken to reach the solution): (1.5 points)

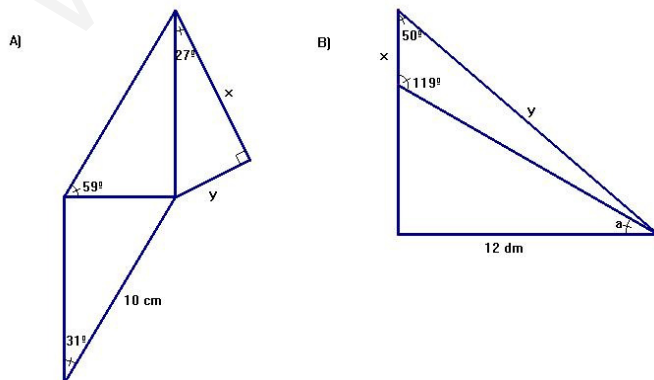

### SOLUTION

1. A tower casts a shadow of 64 feet. A 6-foot tall pole near the tower casts a shadow 8 feet long. How tall is the tower?

Similar triangles, they have three congruent angles

$$\frac{x}{64} = \frac{6}{8} \Rightarrow x = \frac{6 \times 64}{8} = 48$$

The tower is 48 feet tall

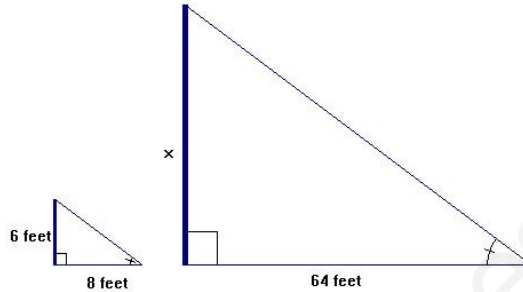

2. A fireman rests his ladder against a building, making a  $57^\circ$  angle with the ground. The bottom of the ladder is 28 feet from the base of the building. How long is the ladder?

$$\cos 57^\circ = \frac{28}{x} \rightarrow x = \frac{28}{\cos 57^\circ} = 51.41 \text{ feet}$$

The ladder is 51.41 feet long

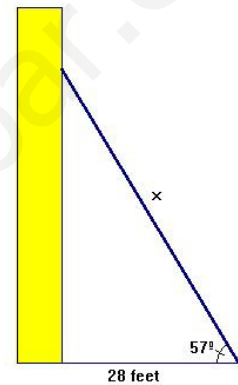

2. In each triangle find the missing length:

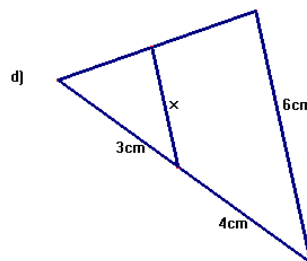
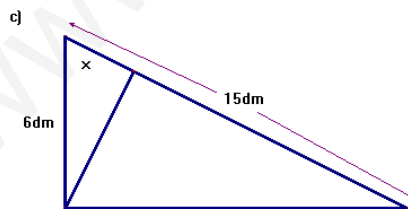
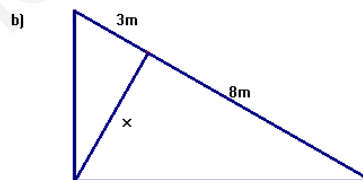
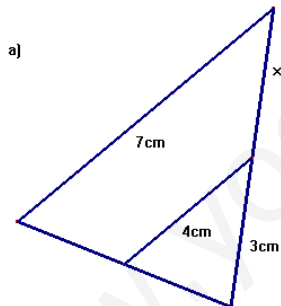

a) Similar triangles (parallel lines, congruent angles)

$$\frac{7}{4} = \frac{3+x}{3} \Rightarrow 3+x = \frac{21}{4} \rightarrow x = \frac{21}{4} - 3 = \frac{9}{4} \rightarrow x = 2.25\text{cm}$$

b) Height Theorem

$$x^2 = 3 \times 8 = 24 \rightarrow x = \sqrt{24} = 2\sqrt{6}\text{m}$$

c) Leg Theorem

$$6^2 = 15x \rightarrow 36 = 15x \rightarrow x = \frac{36}{15} = 2.4 \text{ dm}$$

d) Similar triangles (parallel lines, congruent angles)

$$\frac{7}{3} = \frac{6}{x} \Rightarrow 7x = 18 \rightarrow x = \frac{18}{7} \rightarrow x = 2.57 \text{ cm}$$

3. A rhombus has sides of length 8 cm and two congruent angles of  $130^\circ$ . Find the length of the longer diagonal of the rhombus and the other angles.

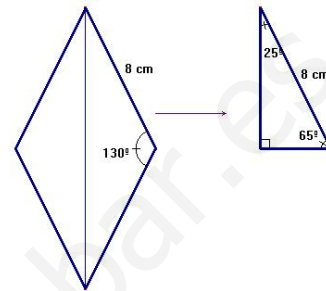

The other angles:  $50^\circ$  ( $180 - 90 - 65 = 25$ )

$$\sin 65^\circ = \frac{x}{8} \Rightarrow x = \sin 65^\circ \times 8 \rightarrow x = 7.25 \text{ cm}$$

Diagonal:  $D = 2x = 2 \times 7.25 = 14.5 \text{ cm}$

4. Solve the simultaneous equations: 
$$\left. \begin{aligned} y^2 - 2y + 1 &= x \\ \sqrt{x} + y &= 5 \end{aligned} \right\} \rightarrow y = 5 - \sqrt{x}$$

$$\begin{aligned} (5 - \sqrt{x})^2 - 2(5 - \sqrt{x}) + 1 &= x \rightarrow 25 - 10\sqrt{x} + x - 10 + 2\sqrt{x} + 1 = x \\ 25 - 8\sqrt{x} + x - 10 + 1 - x &= 0 \rightarrow -8\sqrt{x} = -16 \rightarrow \sqrt{x} = 2 \rightarrow x = 4 \\ y = 5 - \sqrt{x} &= 5 - 2 = 3 \quad \text{Solution: } x = 4, y = 3 \end{aligned}$$

5. In each triangle find the missing lengths and/or angles:

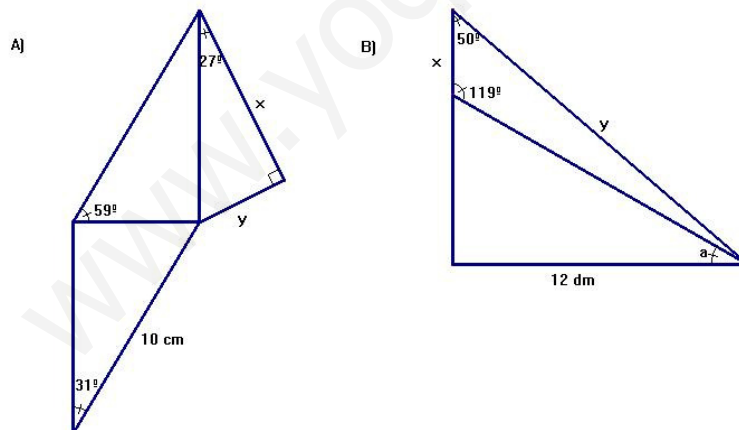

A) Two congruent triangles, they have congruent angles ( $90^\circ$ ,  $59^\circ$  and  $31^\circ$ ) and a congruent side.

$$\cos 31^\circ = \frac{z}{10} \rightarrow z = 10 \times \cos 31^\circ = 8.57 \text{ cm}$$

$$\cos 27^\circ = \frac{x}{8.57} \rightarrow x = 8.57 \times \cos 27^\circ = 7.64 \text{ cm}$$

$$\sin 27^\circ = \frac{y}{8.57} \rightarrow y = 8.57 \times \sin 27^\circ = 3.89 \text{ cm}$$

$$\text{B) } 180^\circ - (119^\circ + 50^\circ) = 11^\circ; \quad 180^\circ - 119^\circ = 61^\circ; \quad \hat{a} = 180^\circ - (90^\circ + 61^\circ) = 29^\circ$$

$$\tan 29^\circ = \frac{a}{12} \rightarrow a = 12 \times \tan 29^\circ = 6.65 \text{ dm}$$

$$\tan(29^\circ + 11^\circ) = \tan 40^\circ = \frac{z}{12} \rightarrow z = 12 \times \tan 40^\circ = 10.07 \text{ dm}$$

$$x = 10.07 - 6.65 = 3.42 \text{ dm}$$

$$y^2 = 12^2 + z^2 = 144 + 10.07^2 = 245.4049 \rightarrow y = 15.67 \text{ dm}$$